

Z45XC-2 BS Flanged Resilient NRS Gate Valve, with Post Flange PN16, UL/FM Approved

Product Description

Product Certification

UL Listed / FM Approved (EX 15973)

Connection Ends

Flange to BS EN 1092-2:1997

Working Pressure

PN16

Temperature Range

0°C - 100°C

Coating

Fusion Bonded Epoxy Coating in accordance with ANSI/AWWA C550



Materials of Construction

Part No.	Part	Standard Specification
1	Valve Body	EN-GJS-450-10
2	Resilient Wedge Disc	EN-GJS-450-10+EPDM
3	Stem	Stainless Steel
4	Bolt	Carbon Steel Zinc Plated
5	Bonnet	EN-GJS-450-10
6	O-Ring	NBR
7	Gland	EN-GJS-450-10
8	Stem Cap	EN-GJS-450-10
9	Bolt	Carbon Steel Zinc Plated
10	Ring Wiper	NBR
11	Bolt	Carbon Steel Zinc Plated
12	Flat Washer	Carbon Steel Zinc Plated
13	O-Ring	NBR
14	Thrust Washer	Brass HPb59-1 (Type A)
15	Bonnet Gasket	EPDM
16	Wedge Nut	Brass HPb59-1
17	Post Flange	EN-GJS-450-10

Dimensions (in mm)

Inch	mm	L	H (Max)	D	D1 (P.C.D.)	n-Ød
4"	100	229	395	220	180	8-Ø19
5"	125	254	432	250	210	8-Ø19
6"	150	267	475	285	240	8-Ø23
8"	200	292	585	340	295	12-Ø23
10"	250	330	656	405	355	12-Ø28
12"	300	356	751	460	410	12-Ø28
14"	350	381	952	520	470	16-Ø28
16"	400	406	952	580	525	16-Ø31

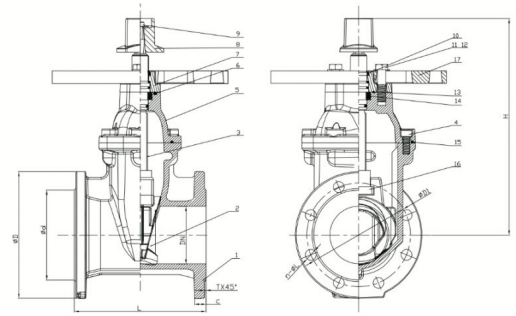

Notes

1. Product images are for illustration purposes only. Actual product may vary.
2. Actual dimensions may change over time, due to continual design improvements. Please confirm before placing order.